



**Hydro One Networks Inc.**  
483 Bay Street  
Toronto, Ontario  
M5G 2P5

**NEEDS ASSESSMENT REPORT**

**Region: Greater Ottawa**

**Date: December 20, 2022**

**Prepared by: Greater Ottawa Region Technical Working Group**



Page intentionally left blank

**Disclaimer**

This Needs Assessment Report was prepared for the purpose of identifying potential needs in the Greater Ottawa Region and to recommend which need may be a) directly addressed by developing a preferred plan as part of NA phase and b) identify needs requiring further assessment and/or regional coordination. The results reported in this Needs Assessment are based on the input and information provided by the Technical Working Group (TWG) for this region.

The TWG participants, their respective affiliated organizations, and Hydro One Networks Inc. (collectively, “the Authors”) shall not, under any circumstances whatsoever, be liable to each other, to any third party for whom the Needs Assessment Report was prepared (“the Intended Third Parties”) or to any other third party reading or receiving the Needs Assessment Report (“the Other Third Parties”). The Authors, Intended Third Parties and Other Third Parties acknowledge and agree that:

- (a) the Authors make no representations or warranties (express, implied, statutory, or otherwise) as to this document or its contents, including, without limitation, the accuracy or completeness of the information therein;
- (b) the Authors, Intended Third Parties and Other Third Parties and their respective employees, directors and agents (the “Representatives”) shall be responsible for their respective use of the document and any conclusions derived from its contents;
- (c) and the Authors will not be liable for any damages resulting from or in any way related to the reliance on, acceptance or use of the document or its contents by the Authors, Intended Third Parties or Other Third Parties or their respective Representatives.

## Executive Summary

**REGION** Greater Ottawa Region (the “Region”)

**LEAD** Hydro One Networks Inc. (“HONI”)

**START DATE:** August 23, 2022

**END DATE:** December 20, 2022

### 1. INTRODUCTION

The second regional planning cycle for the Greater Ottawa Region was completed in December 2020 with the publication of the Regional Infrastructure Plan (“RIP”) report. This is the third cycle of regional planning for the region, which begins with the Needs Assessment (“NA”) phase. The purpose of this NA is to:

- a) Identify any new needs and reaffirm needs identified in the previous regional planning cycle; and,
- b) Recommend which needs:
  - (i) require further assessment and regional coordination (and hence, proceed to the next phases of regional planning); and,
  - ii) do not require further regional coordination (i.e., can be addressed directly between Hydro One and the impacted LDC(s) to develop a preferred plan and/or no regional investment is required at this time and the need may be reviewed during the next regional planning cycle).

### 2. REGIONAL ISSUE/TRIGGER

In accordance with the Regional Planning process, the regional planning cycle should be triggered at least once every five years. Due to an increase in load growth in the region, the Technical Working Group (“TWG”) met in April 2022 and decided that the 3<sup>rd</sup> Regional Planning cycle be triggered in advance of the five-year period.

### 3. SCOPE OF NEEDS ASSESSMENT

The scope of the Greater Ottawa Region NA includes:

- a) Reaffirm and update needs/plans identified in the previous regional planning cycle RIP;
- b) Identify any new needs resulting from this assessment;
- c) Recommend which need(s) require further assessment and regional coordination in the next phases of the regional planning cycle; and,
- d) Recommend which needs do not require further regional coordination (i.e., can be addressed directly between Hydro One and the impacted LDC(s) to develop a preferred plan and/or no regional investment is required at this time and the need may be reviewed during the next regional planning cycle).

The TWG may also identify additional needs during the next phases of the planning process, namely Scoping Assessment (“SA”), Integrated Regional Resource Plan (“IRRP”) and Regional Infrastructure Plan (RIP), based on updated information available at that time.

The planning horizon for this NA assessment is 10 years.

### 4. INPUTS/DATA

The TWG representatives from Local Distribution Companies (“LDC”), the Independent Electricity System Operator (“IESO”), and Hydro One provided input and relevant information for the Greater Ottawa Region regarding capacity needs, system reliability, operational issues, and major high-voltage (HV) transmission equipment requiring replacement over the planning horizon.

## 5. ASSESSMENT METHODOLOGY

The assessment's primary objective is to identify the electrical infrastructure needs in the Region over the study period. The assessment methodology includes a review of planning information such as load forecast, conservation and demand management ("CDM") forecast, distributed generation ("DG") forecast, system reliability and operation, and major HV transmission assets requiring replacement.

A technical assessment of needs was undertaken based on:

- a) Station capacity and transmission adequacy;
- b) System reliability and any operational concerns;
- c) Major HV transmission equipment requiring replacement with consideration to "right-sizing"; and,
- d) Sensitivity analysis to capture uncertainty in the load forecast as well as variability of demand drivers such as electrification.

## 6. NEEDS

### I. Update on needs identified during the previous regional planning cycle

The following needs and projects discussed in the Greater Ottawa 2<sup>nd</sup> Cycle RIP report have been completed:

- Hawthorne T5/T6 autotransformer replacement was completed in 2021;
- King Edward TS transformer T3 replacement was completed in 2021;
- Cambrian MTS was in-serviced in 2022;
- Overbrook TS LV transformer cable capacity limitation review. Hydro One has completed its review of the LV cables and determined they are not limiting the station LTR.

#### a) 115kV Transmission Supply Capacity

- L2M Supply Capacity: The loading line section between Merivale TS and Limebank MTS has been reassessed is expected to reach its limit in 2031 based on the net extreme summer weather coincident peak load forecast.

#### b) Transformation Capacity

- Kanata-Stittsville Capacity: Based on the net extreme summer weather non-coincident peak load forecast, Marchwood MTS, Kanata MTS and Terry Fox MTS are expected to exceed their respective station capacity limits during the study period.

#### c) Voltage Performance

- Monitor voltage on line 79M1. As a result of the long distance and circuit loading on 115 kV circuit 79M1, lower voltage is expected at the end of the line.

The remaining near/medium-term needs and projects discussed in the Greater Ottawa 2<sup>nd</sup> Cycle RIP report are underway and an update on their status is discussed in section 7 of this report.

### II. Newly identified needs

The following are new needs that were identified as part of this assessment:

**d) Asset Renewal for Major HV Transmission System Equipment**

Based on asset condition assessment, the following asset renewal needs have been identified over the planning horizon:

- Lisgar TS: Replace transformer T1
- South March TS: Replace transformers T1/T2
- S7M Line Refurbishment

**e) Transformation Capacity**

- Many areas are growing and have stations near or exceeding their limits, please refer to the load forecast in Appendix A. While load transfers can mitigate the need in the near term, station capacity should be reviewed as part of this cycle.

## 7. RECOMMENDATIONS

The TWG's recommendations are as follows:

- a) Further assessment and regional coordination is required in the next phases of the regional planning cycle to develop a preferred plan for the following needs:
  - Asset renewal needs for South March TS and Lisgar TS to right-size the transformer replacement (discussed in sections 7.1.1 and 7.1.2);
  - Asset renewal needs for sections of circuit S7M to determine prefer supply configuration for the area (discussed in section 7.1.4);
  - L2M Supply Capacity (discussed in section 7.2.2); and,
  - Review of station transformation capacity, including the Kanata-Stittville capacity need (discussed in section 7.2.3).

## TABLE OF CONTENTS

1	Introduction .....	8
2	Regional Issue/Trigger .....	8
3	Scope of Needs Assessment .....	9
4	Regional Description and Connection Configuration .....	9
5	Inputs and Data .....	14
6	Assessment Methodology .....	14
7	Needs.....	18
8	Sensitivity Analysis.....	29
9	Conclusion and Recommendations .....	30
10	References .....	31
	Appendix A: Extreme Summer Weather Net Non-Coincident Load Forecast .....	32
	Appendix B: Distributors in the Greater Ottawa Region .....	36
	Appendix C: Lists of Transmission Circuits.....	38
	Appendix D: Acronyms .....	39

### List of Figures

Figure 1: Map of Greater Ottawa Regional Planning Area.....	10
Figure 2: Ottawa Area Sub-region Map.....	11
Figure 3: Outer Ottawa Sub-region Map (Eastern Area) .....	11
Figure 4: Outer Ottawa Sub-region Map (Western Area).....	12
Figure 5: Greater Ottawa Region Single Line Diagram.....	13
Figure 6: Existing east Ottawa system (red – 230kV; green 115kV).....	16
Figure 7: Proposed East Ottawa system configuration - Option 1 (red – 230kV; green 115kV). .....	17
Figure 8: Proposed East Ottawa system configuration - Option 2 (red – 230kV; green 115kV). .....	17
Figure 9: 115kV Circuit S7M with Sections Requiring Replacement Identified. ....	23
Figure 10: Merivale autotransformer loading under normal condition.....	24
Figure 11: Merivale autotransformer loading under contingency condition.....	24
Figure 12: Existing Hawthorne autotransformer loading under normal condition. ....	25
Figure 13: Existing Hawthorne autotransformer loading under contingency conditions. ....	25
Figure 14: East Ottawa stations supplied by 115kV circuits H9A and 79M1 .....	28

### List of Tables

Table 1: Greater Ottawa Region TWG Participants .....	8
Table 2: Near/Medium Term Needs Identified in Previous RIP and/or this NA .....	19
Table 3: New Asset Renewal Needs over the next 10 years .....	20
Table 4: Previously identified Asset Renewal Needs occurring over the next 10 years .....	21
Table 5: Adequacy of Step-Down Transformer Stations. ....	27
Table 6: Needs Resulting from Sensitivity Analysis .....	29

## 1 INTRODUCTION

The second cycle of the Regional Planning process for the Greater Ottawa Region was completed in December 2020 with the publication of the Regional Infrastructure Plan (“RIP”) Report.

The purpose of this Needs Assessment (“NA”) is to identify any new needs in the region, reaffirm and update needs identified in the previous Greater Ottawa regional planning cycle, and recommend which needs require further assessment and regional coordination and which do not.

This report was prepared by the Greater Ottawa Region Technical Working Group (“TWG”), led by Hydro One Networks Inc. Participants of the TWG are listed below in Table 1. The report presents the results of the assessment based on information provided by Hydro One, the Local Distribution Companies (“LDC”) and the Independent Electricity System Operator (“IESO”).

Table 1: Greater Ottawa Region TWG Participants

1	Hydro 2000
2	Hydro Hawkesbury
3	Hydro One Networks (Distribution)
4	Hydro One Networks (Lead Transmitter)
5	Hydro Ottawa Limited
6	Independent Electricity System Operator
7	Ottawa River Power Corporation
8	Renfrew hydro

## 2 REGIONAL ISSUE/TRIGGER

In accordance with the regional planning process, the regional planning cycle should be triggered at least once every five years. Due to an increase in load growth in the region, the TWG met in April 2022 and decided that the third Regional Planning cycle be triggered in advance of the 5-year period.



### 3 SCOPE OF NEEDS ASSESSMENT

The scope of this NA covers the Greater Ottawa region and includes:

- Reaffirm and update needs/plans identified in the previous regional planning cycle RIP;
- Identify any new needs resulting from this assessment;
- Recommend which need(s) require further assessment and regional coordination in the next phases of the regional planning cycle; and,
- Recommend which needs do not require further regional coordination (i.e., can be addressed directly between Hydro One and the impacted LDC(s) to develop a preferred plan and/or no regional investment is required at this time and the need may be reviewed during the next regional planning cycle).

The TWG may identify additional needs during the next phases of the regional planning process, namely Scoping Assessment (“SA”), IRRP, and/or RIP based on best available information at that time.

The planning horizon of this NA assessment is 10 years.

### 4 REGIONAL DESCRIPTION AND CONNECTION CONFIGURATION

The Greater Ottawa Region covers the municipalities bordering the Ottawa River from Arnprior in the west to Hawkesbury in the east and north of Highway 43. At the center of this Region is the City of Ottawa. Please see Figure 1 for the map of the Greater Ottawa region. Electrical supply to the region is provided from fifty-two (52) 230kV and 115kV step-down transformer stations.

Bulk electrical supply to the Greater Ottawa Region is provided through the 500/230kV autotransformers at Hawthorne TS and a network of 230kV and 115kV transmission lines and step-down transformation facilities.

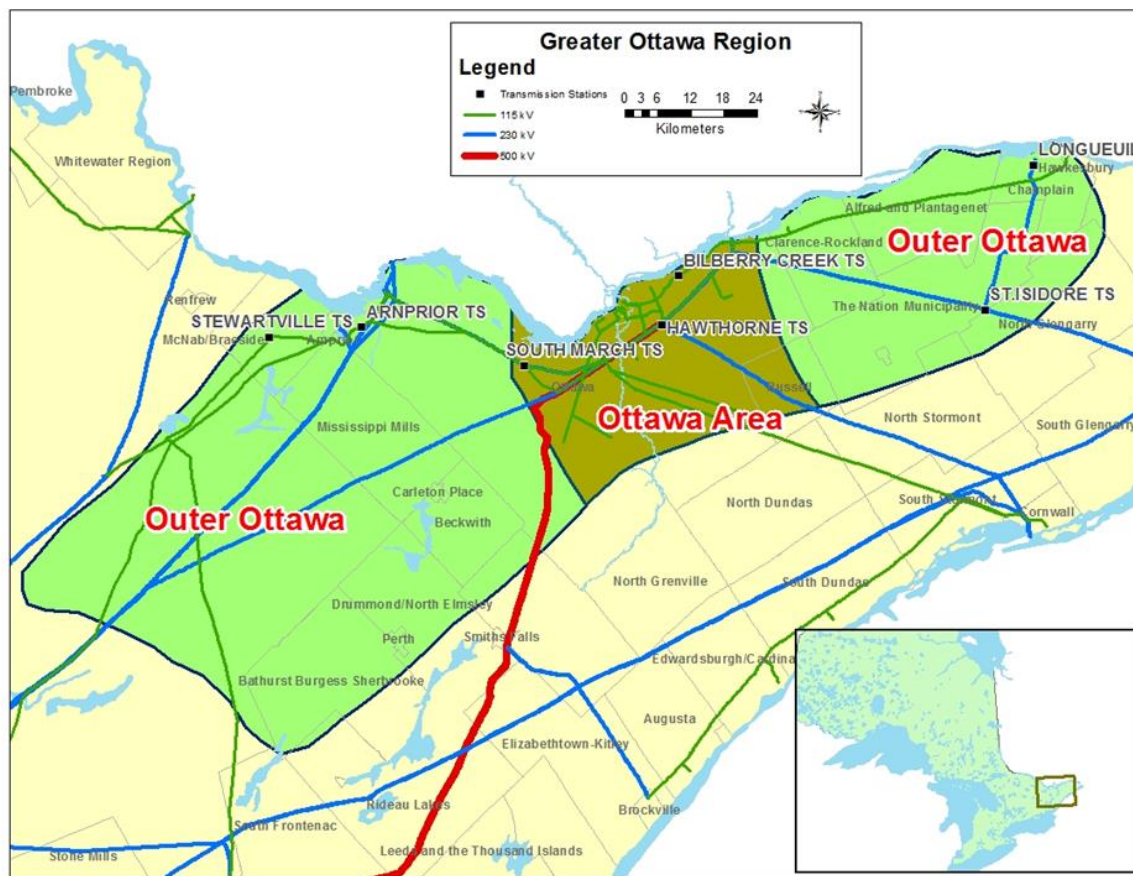

Figure 1: Map of Greater Ottawa Regional Planning Area

As shown in Figure 1, the region is divided into two (2) subregions: The Outer Ottawa and Ottawa Area subregions.

The Ottawa Area Sub-region comprises primarily the City of Ottawa. It is supplied by two (2) 230/115 kV autotransformer stations (Hawthorne TS and Merivale TS), eight (8) 230 kV and thirty-three 115 kV transformer stations stepping down to a lower voltage. Local generation in the area consists of the 74 MW Ottawa Health Science Non-Utility Generator (“NUG”) located near the downtown area and connected to the 115 kV network. The Ottawa Area Sub-region is shown in Figure 2 below. Hydro Ottawa is the main LDC that serves the electricity demand for the City of Ottawa. Hydro One Distribution supplies load in the outlying areas of the sub-region. Both Hydro Ottawa and Hydro One Distribution receive power at the step-down transformer stations and distribute it to end users, including industrial, commercial, and residential customers.

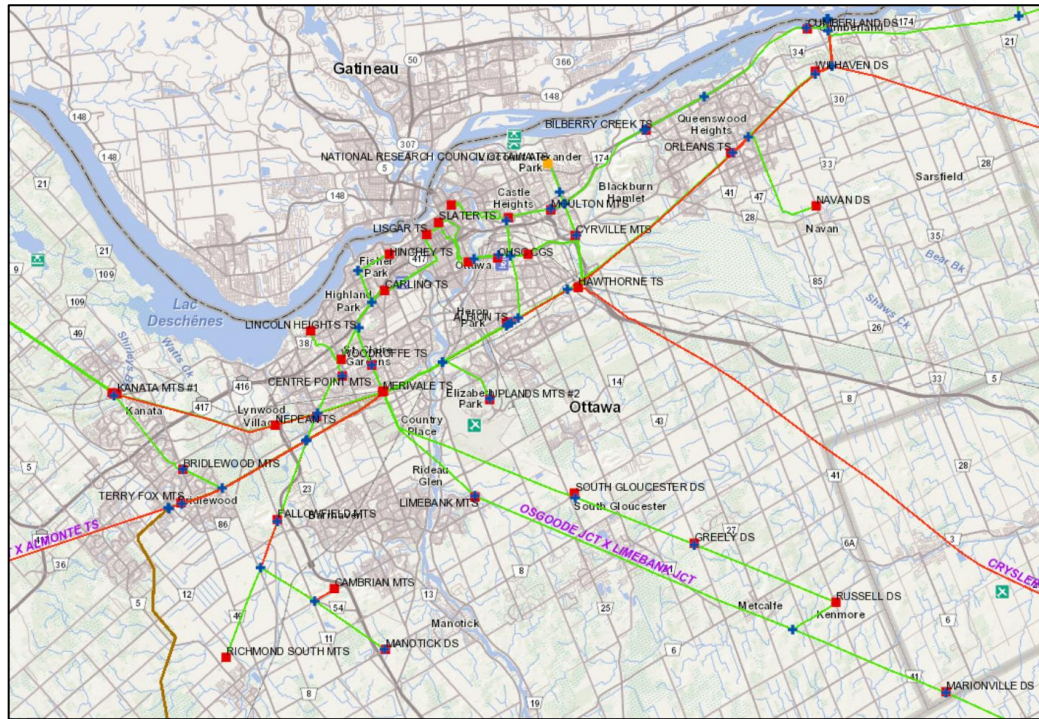

Figure 2: Ottawa Area Sub-region Map

The Outer Ottawa Sub-Region covers the remaining area of the Greater Ottawa Region. The eastern area (shown in Figure 3) is served by three (3) 230kV and five (5) 115kV step-down transformer stations. Hydro One Distribution and Hydro Hawkesbury are the LDCs in the area that distribute power from the stations to their end use customers. Hydro 2000 is embedded LDC that supplies its customers from Longueuil TS via Hydro One Distribution’s 44kV feeders. This area also includes a large industrial customer in L’Orignal, Ontario.

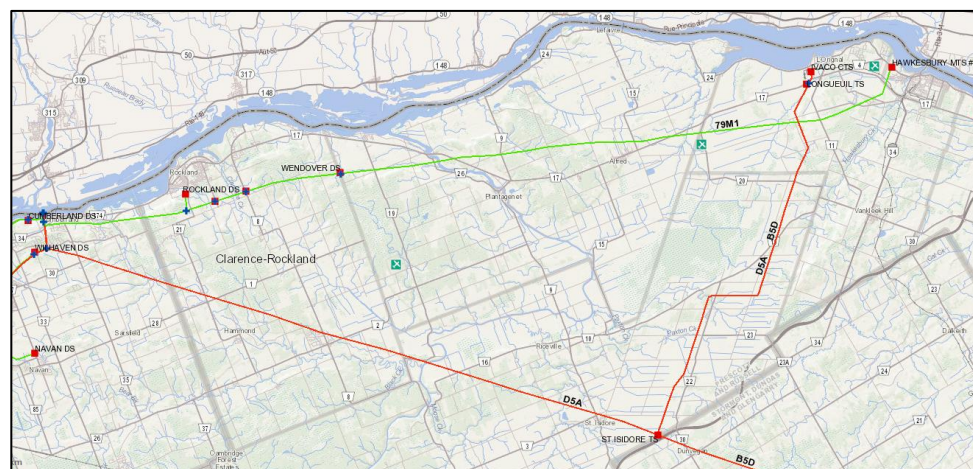

Figure 3: Outer Ottawa Sub-region Map (Eastern Area)

The western area of the Outer Ottawa Sub-Region, shown in Figure 4, is served by one (1) 230kV and two (2) 115kV step-down transformer stations. Hydro One Distribution is the LDC that supplies its end use customers from these stations. Ottawa River Power Corp. is embedded LDC that supplies its customers from Almonte TS via Hydro One Distribution’s 44kV feeders. Renfrew Hydro is embedded LDC that supplies its customers from Stewartville TS via Hydro One Distribution’s 44kV feeders. The area includes the following generating stations: Barrett Chute GS, Chats Falls GS, and Stewartville GS with a peak generation capacity of about 450 MW.

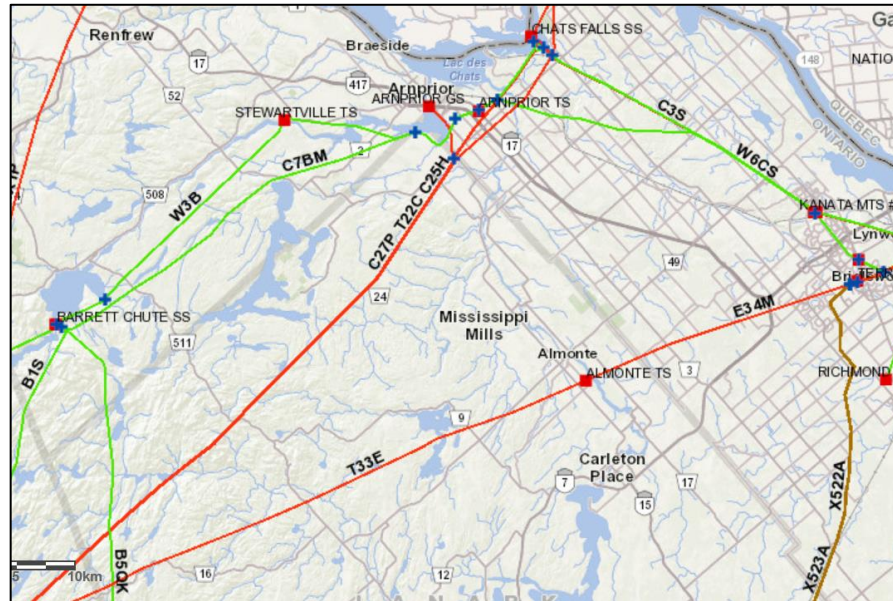

Figure 4: Outer Ottawa Sub-region Map (Western Area)

The existing Greater Ottawa Region transmission single line diagram is shown in Figure 5 below.

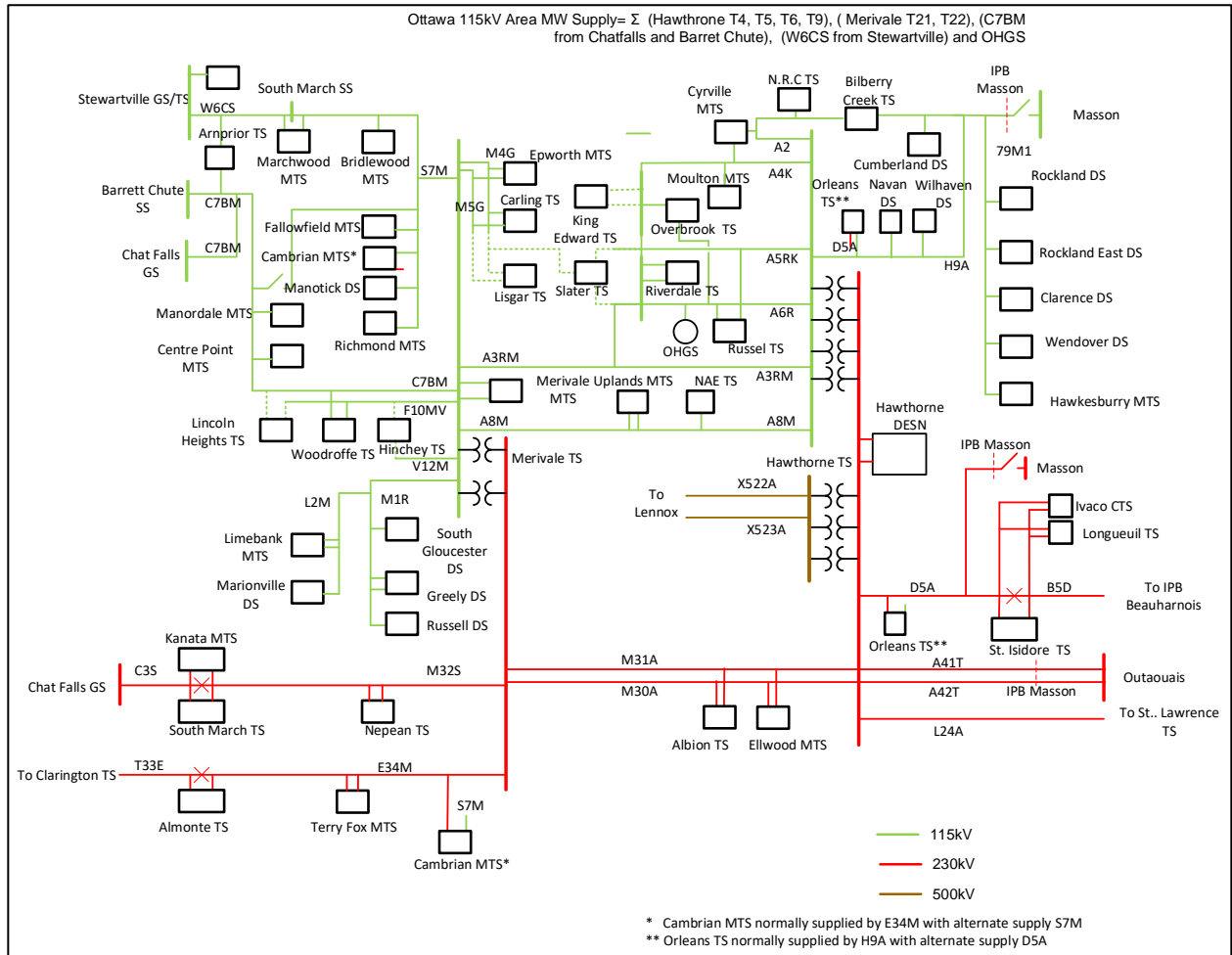

Figure 5: Greater Ottawa Region Single Line Diagram

## 5 INPUTS AND DATA

Technical Working Group (TWG) participants, including representatives from LDCs, IESO, and Hydro One, provided information and input for the Greater Ottawa NA. The information provided includes the following:

- Greater Ottawa Load Forecast for all supply stations;
- Known capacity and system reliability needs, operational issues, and/or major HV transmission equipment requiring replacement over the study period; and,
- Planned/foreseen transmission and distribution investments that are relevant to regional planning for the Greater Ottawa Region.

With respect to the load forecast information, the OEB Regional Planning Process Advisory Group (RPPAG) recently published a document called “Load Forecast Guideline for Ontario” in Oct. 2022. The objective of this document is to provide guidance to the TWG in the development of the load forecasts used in the various phases of the regional planning process with a focus on the NA and the IRRP. One of the inputs into the LDC’s load forecast that is called for in this guideline is information from Municipal Energy Plans (MEP) and/or Community Energy Plans (CEP). Accordingly, the OEB RPPAG also recently developed a guideline called “Improving the Electricity Planning Process in Ontario: Enhanced Coordination between Municipalities and Entities in the Electricity Sector”, which lists the key MEP/CEP outputs to improve LDC load forecasts going forward. Hydro One has undertaken a screening of CEPs in the area, such as the City of Ottawa CEP and found some visionary information to reduce greenhouse gases that could have an impact due to electrification. The TWG recommends that further engagement and analysis be undertaken during the next phases of regional planning.

## 6 ASSESSMENT METHODOLOGY

The following methodology and assumptions are made in this Needs Assessment:

- Load forecast: The LDCs provided their load forecast for all the stations supplying their loads in the Greater Ottawa region for the 10-year study period. The IESO provided a Conservation and Demand Management (“CDM”) and Distributed Generation (“DG”) forecast for the Greater Ottawa region. The region’s extreme summer non-coincident peak gross load forecast for each station was prepared by applying the LDC load forecast growth rates to the actual 2021 summer peak extreme weather corrected loads. The extreme summer weather correction factors were provided by Hydro One. The net extreme summer weather load forecasts were produced by reducing the gross load forecasts for each station by the percentage CDM and then by the amount of effective DG capacity provided by the IESO for that station. It should be noted that as contracts for existing DG resources in the region begin to expire, there will be a decreasing contribution from local DG resources at that point and hence, an increase in net demand. The extreme summer weather corrected net non-coincident peak load forecast for the individual stations in the Greater Ottawa region is given in Appendix A Table A.1. The extreme summer weather corrected net coincident peak load forecast for the individual stations in the Greater Ottawa region is given in Appendix A, Table A.2.

- Sensitivity Analysis: A sensitivity analysis was undertaken by the TWG to capture uncertainty in the load forecast as well as variability of drivers such as electrification. Hence, the NA recommendations are not necessarily linked to sensitivity scenarios; but rather are used to identify any emerging needs for consideration in developing recommendations. The impact of sensitivity analysis for the high and low growth scenarios are provided in section 8 of this report.
- Relevant information regarding system reliability and operational issues in the region; and
- List of major HV transmission equipment planned and/or identified to be replaced based on asset condition assessment, and relevant for regional planning purposes. The scope of equipment considered is given in section 7.1.

A technical assessment of needs was undertaken based on:

- Station capacity and transmission adequacy assessment;
- System reliability assessment and operational considerations;
- Asset renewal for major high voltage transmission equipment requiring replacement with consideration to “right-sizing”; and,
- Sensitivity analysis to capture uncertainty in the load forecast.

The following other assumptions are made in this report.

- The study period for this Needs Assessment is 2022-2031.
- The Region is summer peaking, so this assessment is based on summer peak loads.
- Transmission system adequacy is assessed by using coincident peak loads in the area.
- Station capacity adequacy is assessed by comparing the non-coincident peak load with the station’s normal planning supply capacity, assuming a 90% lagging power factor for stations having no low-voltage capacitor banks and 95% lagging power factor for stations having low-voltage capacitor banks.
- Output of generating stations in the area is based on 98% dependable generation availability for transmission connected run of river hydro-electric stations as per Ontario Resource Transmission Assessment Criteria (ORTAC) criteria.
- Normal planning supply capacity for transformer stations is determined by the Hydro One summer 10-Day Limited Time Rating (LTR) of a single transformer at that station.
- Adequacy assessment is conducted as per Ontario Resource Transmission Assessment Criteria (ORTAC) considering normal and N-1 supply condition.

In addition, several developments since the completion of the last RIP are considered in this report.

- Planned connection of a new Hydro Ottawa 230kV/44kV station near Hawthorne TS on 230kV circuits M30A/M31A to supply a large industrial customer load.
- The Gatineau Corridor EOL Study Report (Gatineau Report) was completed. For the Ottawa area, the recommendations include the refurbishment of sections of 230kV circuit T33E, and up to 230MW of additional system cost-effective energy efficiency in the Ottawa area.

- The Ottawa 115kV System Supply studies recommendations is nearing completion. Based on its recommendation and following discussions between IESO and Hydro One, a third autotransformer will be installed at Merivale TS.
- IESO, Hydro Ottawa and Hydro One reviewed the east Ottawa supply, especially Bilberry Creek TS and Orleans TS. Findings of this study will be published as part of the Ottawa 115kV System Supply study mentioned above. Based on the recommendations of the report, Bilberry Creek TS will be retired instead of refurbished. Transformation capacity will be provided by a new 230kV supply, the connection of a new station and upgrade to existing Orleans TS. The planned in-service for this system configuration change is end of 2027. The existing system and new systems considered are shown in Figure 6, 7, and 8 below. At the time of completing this NA report, the decision on which 230kV supply configuration was not finalized, but system configuration shown in Figure 7 was assumed. Please note, Figure 7 is one of the options considered which changes the 115kV system configuration.

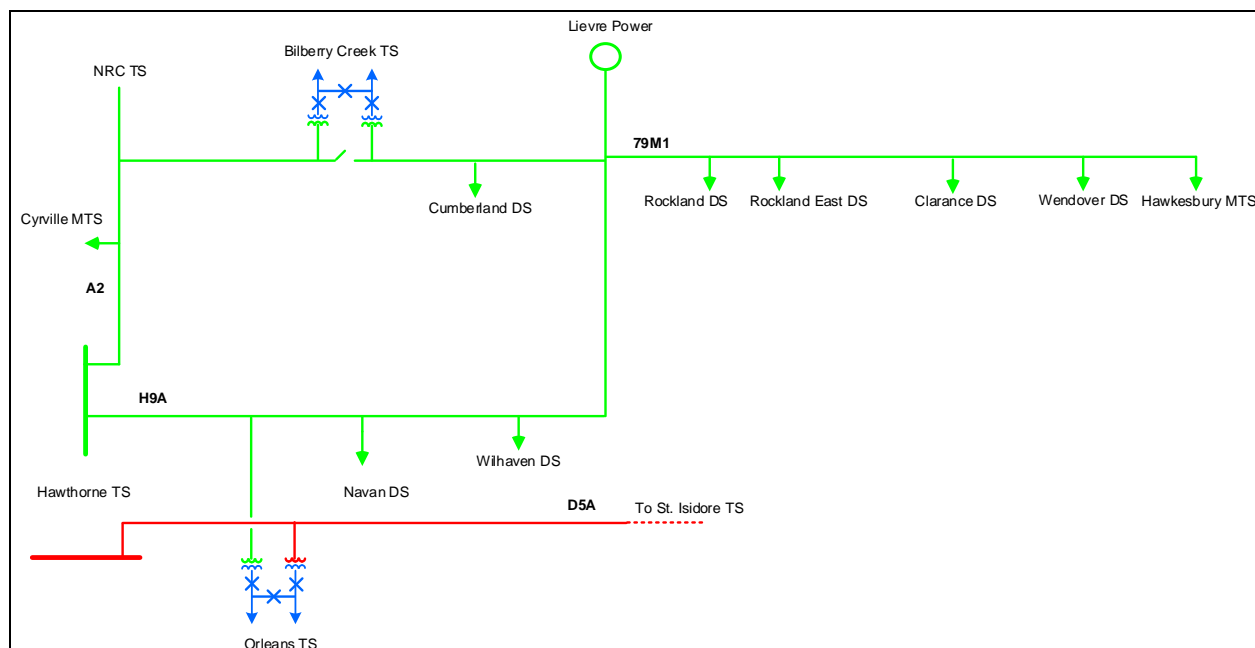

Figure 6: Existing east Ottawa system (red – 230kV; green 115kV).



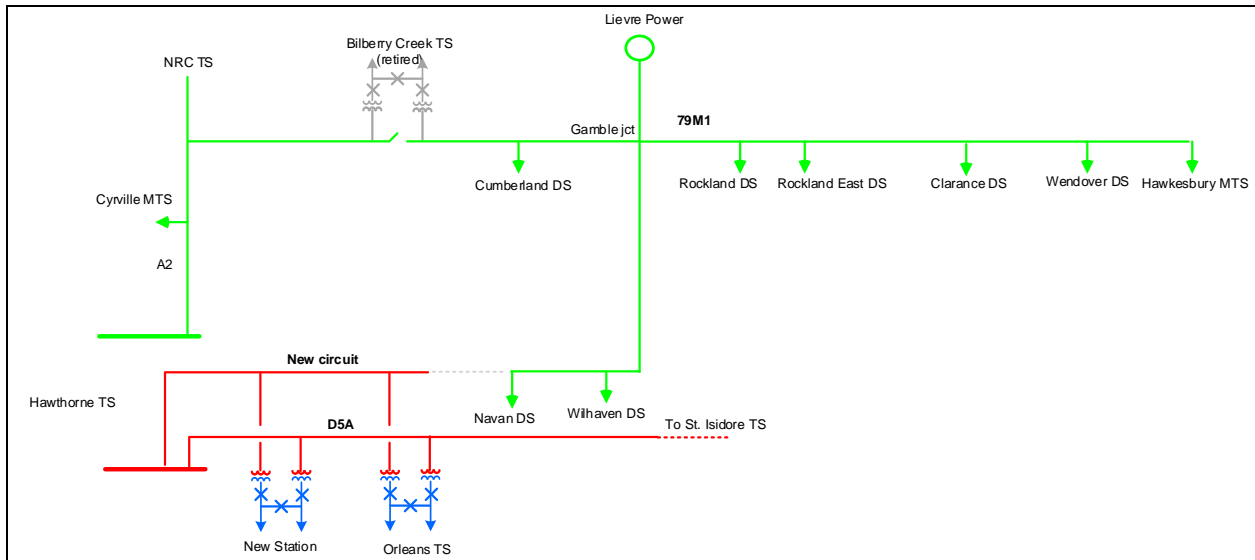

Figure 7: Proposed East Ottawa system configuration - Option 1 (red – 230kV; green 115kV).

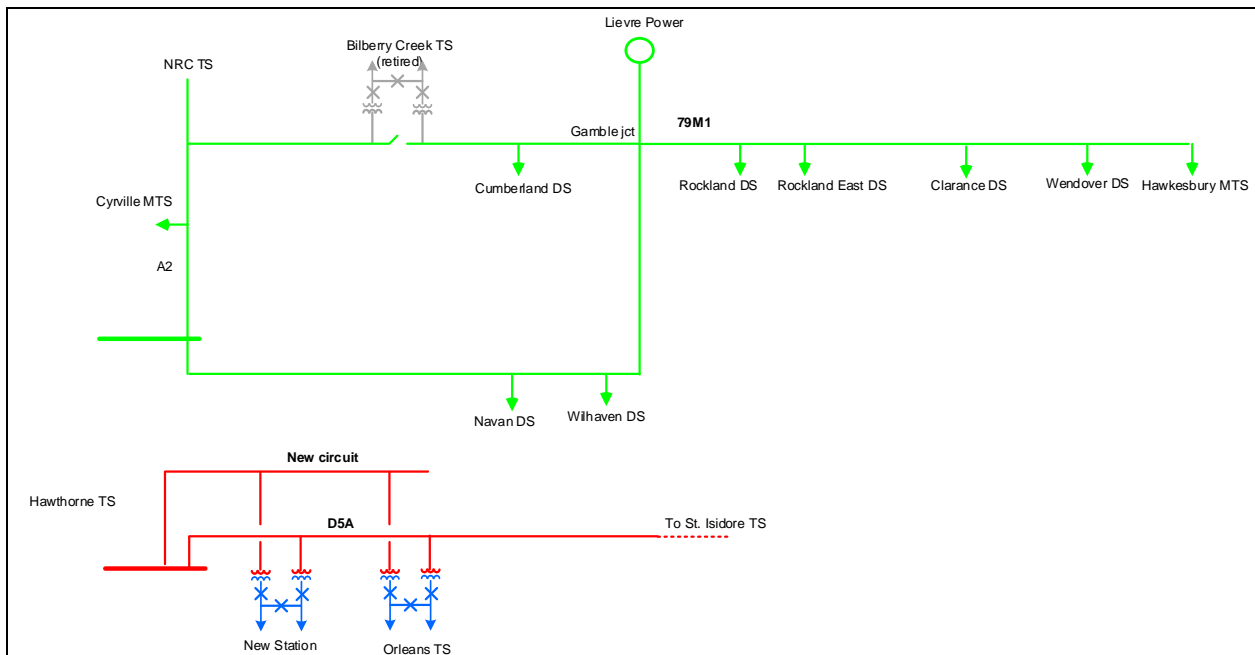

Figure 8: Proposed East Ottawa system configuration - Option 2 (red – 230kV; green 115kV).

## 7 NEEDS

This section identifies any new emerging needs in the Greater Ottawa Region, and reaffirms and provides an update on near, and mid-term needs identified in the previous regional planning cycle.

Needs that were identified and discussed in the previous regional planning cycle with associated projects that were recently completed or underway were reaffirmed and are briefly described below with relevant updates. Asset renewal projects took “right-sizing” into consideration. These projects include:

1. Hawthorne T5/T6 autotransformer replacement was completed in 2021.
2. King Edward TS transformer T3 replacement was completed in 2021.
3. Cambrian MTS was in-serviced in 2022.
4. Overbrook TS LV transformer cable capacity limitation review. Hydro One has completed its review of the LV cables and determined they are not limiting the station LTR.
5. Arnprior TS: Project for like-for-like replacement of transformers T1/T2. The planned in-service date is 2023.
6. M30A/M31A: This capacity upgrade project is intended to increase the power interface limit between Hawthorne TS and Merivale TS by replacing the existing conductor with new twin-bundled 1843.2 kcmil conductor. The project is underway and is being led by Hydro One. The planned in-service date is 2023.
7. Slater TS: Project for replacement of transformers T2/T3 is currently underway and is being led by Hydro One in coordination with Hydro Ottawa. The existing transformers will be upgraded to 60/80/100 MVA unit. The planned in-service date is 2024.
8. Lincoln Heights TS: Project for like-for-like replacement of transformers T1/T2 is underway and is being led by Hydro One in coordination with Hydro Ottawa. The planned in-service date is 2024.
9. Russell TS: Project for replacement of transformers T1/T2 is underway and is being led by Hydro One in coordination with Hydro Ottawa. The transformers will be upgraded with 60/80/100MVA units. The planned in-service date is 2026-2028.
10. Longueuil TS: Project for replacement of transformers T1/T2 is underway and is being led by Hydro One in coordination with Hydro One Distribution. The previous RIP mentioned that the transformers will either be replaced with like-for-like units or upgraded to 75/100/125MVA units. Hydro One and Hydro One Distribution decided to replace both transformers with new like-for-like 50/66.7/83MVA units which will be sufficient based on the current load forecast. The planned in-service date is 2025-2027.
11. Riverdale TS: Project for replacement of two 115kV circuit breakers is underway and is being led by Hydro One in coordination with Hydro Ottawa. The planned in-service date is 2030, but subject to change based on coordination with Hydro Ottawa’s planned work at the station.
12. Albion TS: Project for replacement of transformers T1/T2 with standard size 60/80/100MVA units is underway and is being led by Hydro One in coordination with Hydro Ottawa. The planned in-service date is 2031-2033.
13. Hawkesbury MTS: Project for transformer upgrade with a new 15MVA transformer unit is underway and is being led by Hydro Hawkesbury. The planned in-service date is 2026.

14. Transformation Capacity in South East Ottawa: A new 230kV station connecting to 230kV L24A. This project is underway and is being led by Hydro Ottawa. The planned in-service date in 2026.
15. Merivale TS: project to replace autotransformer T22, six (6) 230kV circuit breakers and four (4) 115kV circuit breakers, and the installation of a new autotransformer T23 is underway and is being led by Hydro One. The in-service date is 2026-2028.

Note: The planned in-service year for the above projects is tentative and is subject to change.

All other near and mid-term needs are summarized in Table 2 below.

Table 2: Near/Medium Term Needs Identified in Previous RIP and/or this NA

Need Description	Recommended Plan/Update	Previous RIP Report Section	NA Report Section
<b>Asset Renewal Needs</b>			
South March TS: transformer T1/T2 transformer replacement	New need identified to replace the two station transformers.	N/A	7.1.1
Lisgar TS: transformer T1 asset replacement.	New need identified to replace transformer T1	N/A	7.1.2
Bilberry Creek TS: transformers T1/T2 and addition of two new LV circuit breakers for Hydro Ottawa.	Plan for Bilberry Creek TS changed based on TWG decision. The station is now planned to be retired. New 230kV circuit, upgrade to Orleans TS, and a new station is now planned. In-service in 2027.	7.6	7.1.3
S7M: line refurbishment	Full line refurbishment plan from Manotick JCT to Richmond MTS, and STR 673N JCT to Manordale JCT	7.1 of second cycle NA	7.1.4
<b>Capacity Needs</b>			
L2M Supply Capacity	Line section between Merivale and Limebank overload. To be reviewed as part of this cycle of regional planning.	7.4	7.2.2
Kanata-Stittsville Area Capacity	Load growth at Marchwood MTS, Kanata MTS and Terry Fox MTS exceeding transformation capacity. Managed through load transfers in short term. Long term solution to be evaluated in this cycle of regional planning	7.2	7.2.3
<b>Voltage Performance Needs</b>			
79M1 voltage	Low voltage at end of circuit.	7.7	7.3.1

## 7.1 Asset Renewal Needs for Major HV Transmission Equipment

In addition to the previously identified asset renewal needs from the second regional planning cycle RIP report (shown in table 4 below), Hydro One and the TWG have identified some new major HV equipment replacement needs over the next 10 years in the Greater Ottawa Region (shown in Table 3 below). These needs are determined by asset condition assessment, which is based on a range of considerations such as equipment deterioration; technical obsolescence due to outdated design; lack of spare parts availability or manufacturer support; and/or potential health and safety hazards, etc. The scope, timing, and prioritization of these replacement needs are based on current available information and are subject to change.

The major high voltage transmission equipment considered in this assessment includes the following:

1. 230/115kV autotransformers;
2. 230 and 115kV load serving step-down transformers;
3. 230 and 115kV breakers where:
  - Replacement of six breakers or more than 50% of station breakers, the lesser of the two
4. 230 and 115kV transmission lines requiring refurbishment where:
  - Leave to Construct (i.e., section 92) approval is required for any alternative to like-for-like.
5. 230 and 115kV underground cable requiring replacement where:
  - Leave to Construct (i.e., section 92) approval is required for any alternative to like-for-like.

The asset renewal assessment considers options for “right-sizing” the equipment such as:

- Maintaining the status quo;
- Replacing equipment with similar equipment with *lower* ratings and built to current standards;
- Replacing equipment with similar equipment with *lower* ratings and built to current standards by transferring some load to other existing facilities;
- Eliminating equipment by transferring all the load to other existing facilities;
- Replacing equipment with similar equipment and built to current standards (i.e., “like-for-like” replacement); and,
- Replacing equipment with higher ratings and built to current standards.

Table 3: New Asset Renewal Needs over the next 10 years

Station	Timing	Need Description	NA Section
South March TS: Transformers T1/T2	2030-32	T1/T2 requires replacement in the medium term.	7.1.2
Lisgar TS: Transformer T1	2031-33	T1 requires replacement in the medium term.	7.1.3

Table 4: Previously identified Asset Renewal Needs occurring over the next 10 years

Station/Circuit	Needs & Recommended Plan	Planned ISD	Previous RIP Report Section
Arnprior TS	Asset replacement need of T1/T2 Transformers: Replace with new 25/33/42 MVA Transformers	2023	4
Slater TS	Asset replacement need of T2/T3 Transformers: Replace with new 60/80/100 MVA Transformers	2024	4
S7M	Line refurbishment: Full line refurbishment plan from Manotick JCT to Richmond MTS, and S7M N1 JCT to Manordale JCT	2024	7.1 of second cycle NA
Lincoln Heights TS	Asset replacement need of T1/T2 Transformers: Replace with new 45/75 MVA Transformers	2024	7.10
Russel TS	Asset replacement need of T1/T2 Transformers: Replace with new 60/100 MVA Transformers	2026/2028	7.14
Longueuil TS	Asset replacement need of T3/T4 Transformers: Replace with new 50/83 MVA Transformers	2025-2027	7.11
Merivale TS	Asset replacement need of T22 autotransformer, 230kV breakers and 115kV oil circuit breakers: Replace with new assets and addition of autotransformer T23 for capacity upgrade.	2026-2028	7.5
Riverdale TS	Asset replacement need of 115kV breakers: Replace with new 115kV breakers	2030	7.12
Albion TS	Asset replacement need of T1/T2 Transformers: Replace with new 60/100 MVA Transformers	2031-2033	7.13
Bilberry Creek TS	Asset replacement need of T1/T2 transformers: Plan modified since the previous RIP, TWG decided to retire the station, and a new station is now planned.	2027	7.6 & 7.1.3 of this NA

Note: The planned in-service year for the above projects is tentative and is subject to change.

### 7.1.1 South March TS

South March TS is supplied from 230kV circuits M32S and C3S. The station supplies Hydro Ottawa and Hydro One Distribution customers.

The station has two (2) 230kV/44kV, 50/67/83MVA transformers that were in-serviced in 1971 and based on their asset condition are in need of replacement. The in-service date will be determined as the project definition progresses and is tentatively planned for 2030-2032. The station LTR is 116.2MW and based on the non-coincident load forecast it is expected to be exceeded by 2026.

The TWG recommends that the capacity need for the area be further reviewed to determine if the transformers should be replaced with similar 50/67/83MVA units or if the size should be upgraded to 75/100/125MVA units.

### 7.1.2 Lisgar TS

Lisgar TS is a transformer station located in the City of Ottawa. The station is supplied by two 115 kV circuits, M4G and M5G. The station supplies electricity to Hydro Ottawa customers. The 10-day summer LTR of the station is 74.7MW. Based on the non-coincident forecast, the station capacity is reached in 2026.

Transformer T2 at the station was replaced in 2011 due to a failure. Transformer T1 was in-serviced in 1974 and based on its asset condition needs replacement. The two (2) transformers at the station are 115kV/13.8kV/13.8kV, 45/60/75MVA transformers. The in-service date will be determined as the project definition progresses and is tentatively planned for 2031-2033 for the replacement of transformer T1.

The TWG recommends the capacity need for the area be further reviewed to determine if the transformer should be replaced with a 45/60/75MVA unit or upgraded to 60/80/100MVA unit.

### **7.1.3 Bilberry Creek TS**

Bilberry Creek TS is a transformer station supplied by two (2) 115 kV circuits A2 and H9A from Hawthorne TS. The station supplies electricity to Hydro Ottawa and Hydro One Distribution customers. The two (2) 50/67/83.3MVA transformers T1 and T2 are 61 years old.

The previous cycle of regional planning had recommended Hydro One proceed with the replacement of the transformers based on asset condition assessment. In addition, two (2) new 27.6kV circuit breakers were to be installed to address Hydro Ottawa's load growth. However, since the completion of the last RIP in 2020, the IESO, Hydro Ottawa and Hydro One met to discuss load growth in the area and other options to supply the growing load in east Ottawa.

An IESO-led study has reviewed different options to address the load growth. Based on the findings of the study, the plan for the area has changed and it was determined that Bilberry Creek TS is no longer required and will be retired. The station will be replaced by a new Hydro Ottawa owned station to serve Hydro Ottawa's load in the area, and by the conversion of existing station Orleans TS to a full 230kV DESN with increased capacity (from its current 230kV and 115kV supply). Please see Figure 6, 7, and 8.

Based on the recommendation of the IESO-led study, the work planned at Bilberry Creek will not proceed. The in-service date for the proposed new supply for the area will be determined as the project definition progresses and is tentatively planned for in-service date by end of 2027.

### **7.1.4 S7M Circuit Refurbishment**

The previous cycle Needs Assessment identified sections of S7M that needs replacement based on their asset condition. Two sections identified were rebuilt as part of the connection of Cambrian MTS. The remaining two sections are shown in Figure 9 and listed below:

- Manotick Jct x Richmond MTS (about 5.2km)
- STR 673N Jct x Manordale MTS (about 1.4km)

These line sections are currently planned for refurbishment in 2024. There is development anticipated in the area that could require change to the supply configuration. The TWG recommends that the need be further reviewed to determine preferred supply option for the area.

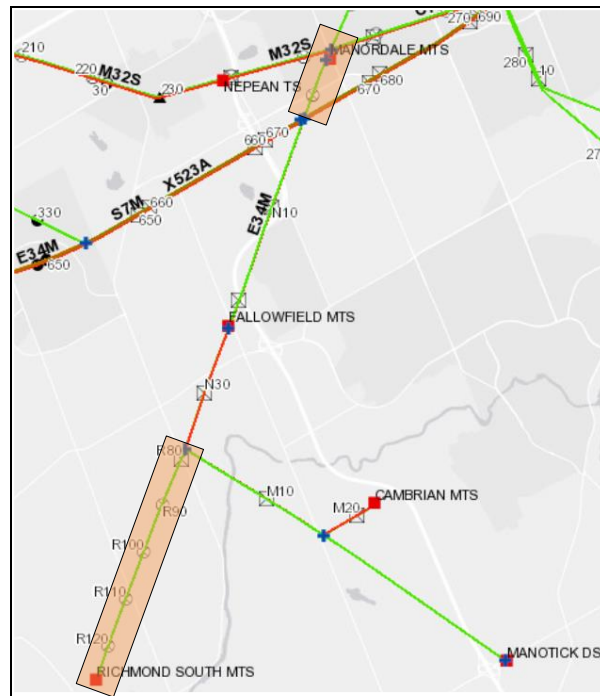

Figure 9: 115kV Circuit S7M with Sections Requiring Replacement Identified.

## 7.2 Station and Transmission Capacity Needs in the Greater Ottawa Region

The station and transmission supply capacities have been reviewed and the following needs have been identified in the Greater Ottawa region during the study period of 2022 to 2031.

### 7.2.1 230/115 kV Autotransformers

Almost sixty percent of the Region load is supplied from the 115 kV transmission system. The primary source of 115 kV supply is from 230/115 kV autotransformers at Hawthorne TS and Merivale TS. Additional support is provided from 115 kV generation at Barrett Chute GS, Stewartville GS, part of Chats Falls GS, and the Ottawa Health Science NUG and the Ottawa River generation at Chaudière as well as distributed generation.

The loading of the autotransformers is sensitive to the availability and dispatch of hydraulic generation from Barrett Chute GS, Stewartville GS, and Chats Falls GS from which the results are based on 98% dependable generation availability as per ORTAC criteria. This corresponds to about 31 MW of available generation.

The previous RIP identified overloading of the continuous and LTR rating of the autotransformers at Merivale TS. Using the coincident forecast, the loading of the autotransformers is shown in Figures 10 and 11 below. As discussed in Section 6, the Ottawa 115kV study is recommending the addition of a third

autotransformer at Merivale, in addition to the replacement of existing autotransformer T22 which was recommended for replacement in the past IRRP. The results shown below have taken into consideration these recommendations and are assuming new T22 and T23.

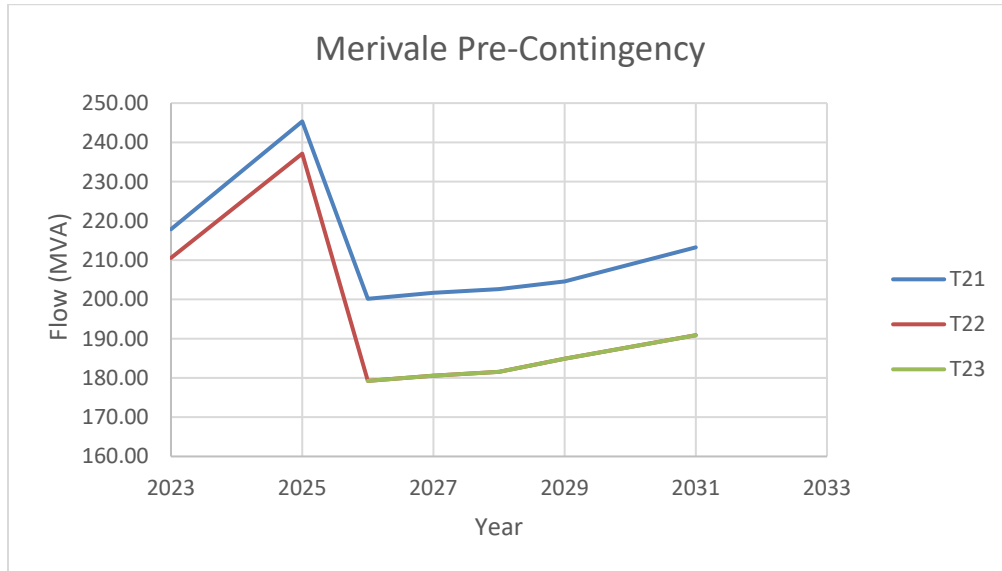

Figure 10: Merivale autotransformer loading under normal condition.

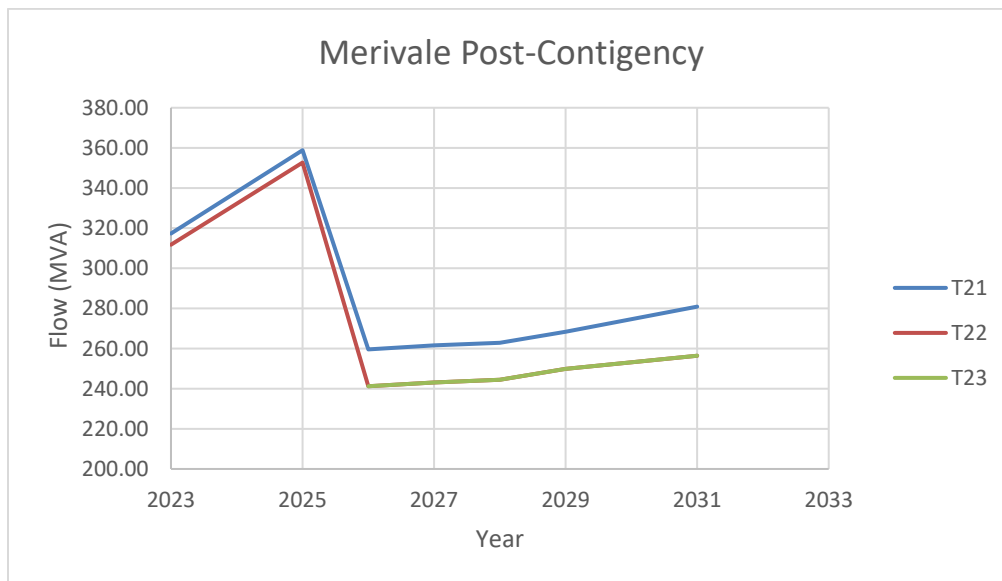

Figure 11: Merivale autotransformer loading under contingency condition.

As can be seen from Figures 10 and 11, following the capacity upgrade at Merivale TS in 2026, the 230/115 kV autotransformers are within their ratings (250MVA continuous, about 340MVA LTR) for the loss of a



single unit and are adequate to supply the forecasted load over the study period. For T22 and T23, loss of T21 was studied and for T21, loss of T22 was studied.

The new autotransformer at Merivale TS also has an impact on the Hawthorne TS autotransformers. Using the updated coincident forecast developed for this NA, the loading of the Hawthorne TS autotransformers is shown in Figures 12 and 13 below.

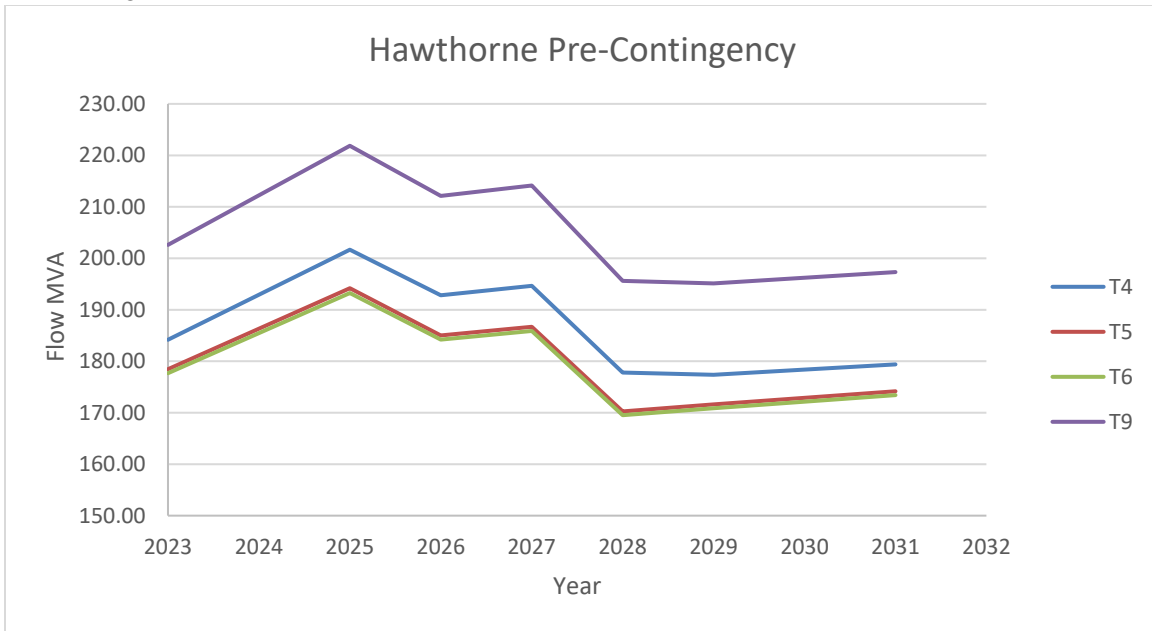

Figure 12: Existing Hawthorne autotransformer loading under normal condition.

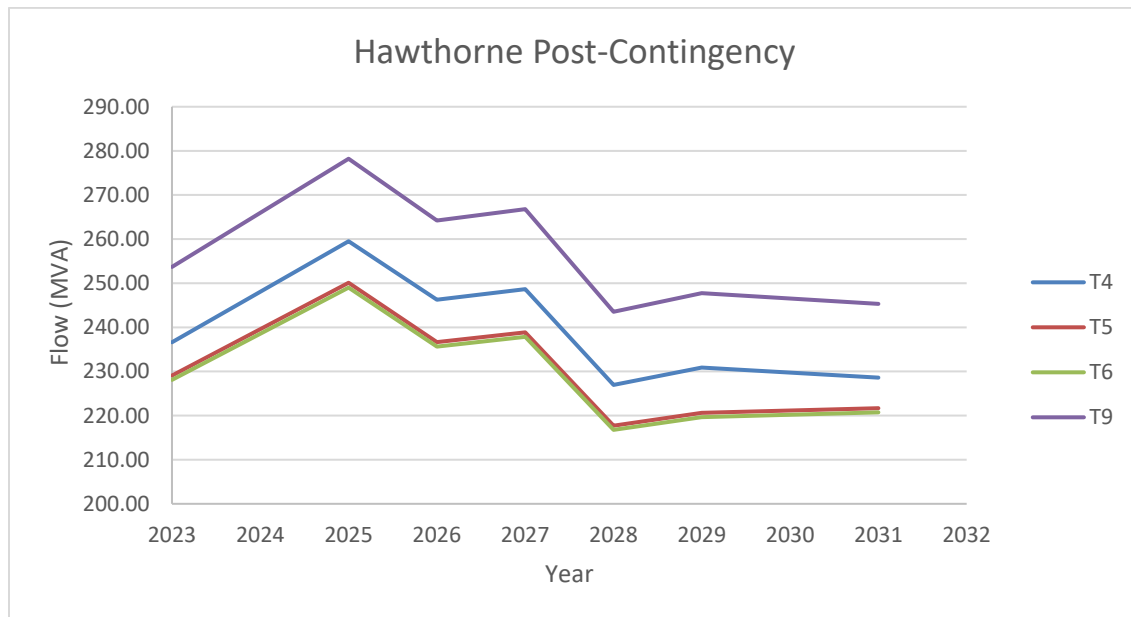

Figure 13: Existing Hawthorne autotransformer loading under contingency conditions.

In Figures 12 and 13, the reduction seen in the autotransformer loading in 2026 is due to the addition of the third autotransformer at Merivale TS. The reduction seen in 2028 is based on the retirement of Bilberry Creek TS and the transfer of load from the 115kV system to the 230kV system. In Figure 11, the most limiting contingency is shown for each autotransformer (the loss of T9 for T4/T5/T6, and the loss of T4 for T9).

As the load is expected to continue to grow beyond 2031, the loading of the autotransformers will continue to be monitored and will also be reviewed as part of the next phases of this regional planning cycle.

### **7.2.2 115kV Transmission Lines**

**L2M Supply Capacity:** L2M is a 115 kV circuit supplying two stations in southern Ottawa from Merivale TS: Limebank MTS and Marionville DS. The circuit extends to St Lawrence TS 115 kV network via a normally opened point at Chesterville TS (fed from St Lawrence TS). Stations transfers between the Merivale L2M network and the St Lawrence L2M network is possible for operating measures. Limebank MTS and Marionville DS are normally radially supplied by L2M from Merivale TS. The circuit is thermally limited to 480A (approximately 86 MW).

The circuit was identified as reaching its limit in 2029 in the previous RIP. Several options were considered to address this capacity need. The decision was made to wait for the conclusion of the Gatineau Study and the Ottawa 115kV Supply study and to re-evaluate the need at the next cycle of regional planning since potential supply changes may be recommended by these reports. No supply changes for the area was recommended as part of these reports.

Re-evaluation of the circuit still identifies it reaching its limit in 2031 based on the coincident load forecast. The TWG recommends that further assessment and regional coordination during the next phases of this regional planning cycle.

### **7.2.3 Station Transformation Capacity**

There is a total of fifty-two step-down transmission connected transformer stations and two industrial customer stations in the Greater Ottawa Region. The stations have been grouped based on the geographical area and transmission supply configuration in Table 5 below. The table below shows the transformation capacity and total demand in each area. However, transfers between stations in each area, or between areas, can be limited by factors such as distribution voltage and availability of feeder ties. This can in turn limit the ability of an area to meet its load growth or address an overload at a station.

Table 5 below shows demand for each area. As can be seen there is significant growth over the study period. Several stations are reaching and/or exceeding their capacity. Please refer to Appendix A for individual station forecast.

Table 5: Adequacy of Step-Down Transformer Stations.

Area	LTR	2022	2023	2024	2025	2026	2027	2028	2029	2030	2031
Center 115kV	614.8	456.6	483.3	503.8	521.0	535.1	544.8	549.8	553.6	552.8	567.2
Center 230kV	290.0 <sup>1</sup>	230.5	238.0	250.9	258.4	266.3	288.3	298.2	313.6	329.3	343.1
East 115kV	421.7 <sup>2</sup>	211.9	216.3	219.9	224.3	228.8	233.4	133.5	136.6	137.1	137.5
East 230kV	123.5 <sup>3</sup>	53.8	54.7	55.5	56.6	58.2	59.4	188.4	189.4	190.5	191.5
Outer East 115kV	56.0	52.4	53.0	53.0	53.1	53.3	53.5	53.7	53.9	54.0	54.2
Outer East 230kV	308.3	156.1	156.6	156.4	156.9	157.3	157.5	158.0	158.5	159.0	161.0
Outer West 115kV	96.6	67.4	68.3	68.7	69.0	69.3	69.5	69.9	69.9	71.7	73.6
Outer West 230kV	104.0	53.4	54.9	55.6	56.6	57.8	58.8	59.9	60.7	65.7	67.5
South 115kV	305.0	195.1	209.3	216.5	228.9	238.9	233.7	250.1	260.4	269.0	276.5
West 115kV	465.5	310.3	318.7	336.6	377.8	390.0	396.4	416.0	423.0	424.5	424.6
West 230kV	488.8	381.6	408.5	434.3	445.6	452.8	452.9	471.7	473.7	489.0	509.9
Total	3251.2	2169.1	2261.7	2351.3	2448.2	2507.7	2548.4	2649.2	2693.2	2742.5	2806.6

<sup>1</sup>Existing total LTR shown. The two new stations are planned in this area will add to the capacity.

<sup>2</sup>Existing total LTR shown. Following retirement of Bilberry Creek TS and conversion of Orleans TS, new LTR is expected to be 208MW.

<sup>3</sup>Existing LTR shown. LTR will increase with the connection of Brian Coburn MTS and conversion of Orleans TS (~162MW).

For many stations, the load increase above the station LTR can be managed through load transfers to nearby stations.

### Ottawa West: Kanata-Stittsville Area

One area where load growth is significant is in the Kanata-Stittsville area, located in the outskirts of the city. This area is supplied by multiple transformer stations, including Kanata MTS, Marchwood MTS, and Terry Fox MTS. Based on the non-coincident forecast, these three stations are expected to be loaded above their LTR over the study period with about 10MW over in 2022, increasing to 47MW in 2031.

This area was identified as a growing area in the previous cycle of regional planning. The conclusion of the RIP report was to review the Gatineau Study EOL report to determine if any recommendation would modify the supply to the area before proceeding with review of wires alternative. In the near term, the overload could be managed through load transfers.

No change of supply to the area was recommended in the report, however up to 230MW of energy efficiency measures were recommended to be implemented in the Ottawa region over the next 20 years.

As part of this cycle of regional planning, the energy efficiency measures should be reviewed for this area in combination with available load transfers to determine the timing for wire alternatives to address this capacity need.

## 7.3 Voltage Performance

### 7.3.1 Voltage on 79M1

The 115 kV circuit 79M1 supplies Rockland DS, Rockland East DS, Clarence DS, Wendover DS, and Hawkesbury MTS as shown in Figure 14. The circuit is supplied from Hawthorne TS via circuit H9A. Total distance to the end station Hawkesbury MTS is approximately 80km. As a result of this long distance and circuit loading, lower voltage can be expected at the end of the line. The previous Greater Ottawa RIP report identified that the voltage at Hawkesbury MTS will approach ORTAC limits under peak load with A2 out of service. The recommendation of the previous RIP report was to continue to monitor the situation and re-evaluate the situation based on the new forecast.

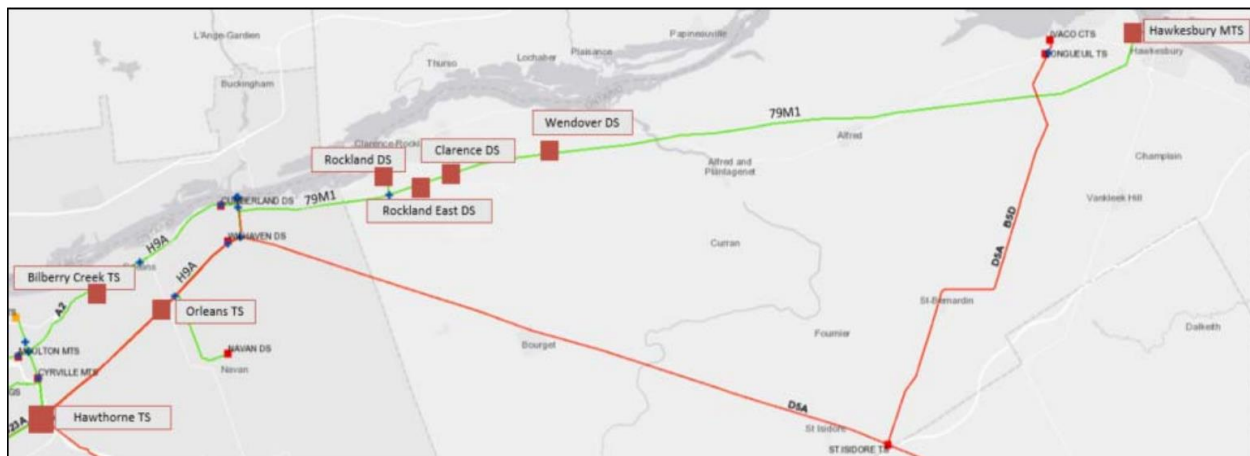

Figure 14: East Ottawa stations supplied by 115kV circuits H9A and 79M1

As discussed in section 7.1, Bilberry Creek TS is planned to be retired and the load move to stations supplied by the 230kV system. Based on this new system configuration, no voltage issues were found over the study period.

## 7.4 System Reliability, Operation and Restoration Review

No new significant system reliability and operating issues have been identified for this Region. Based on the net load forecast, the loss of one element will not result in load interruption greater than 150MW. The maximum load interrupted by configuration due to the loss of two elements is below the load loss limit of 600MW by the end of the 10-year study period.

## 8 SENSITIVITY ANALYSIS

The objective of a sensitivity analysis is to capture uncertainty in the load forecast as well as variability of electric demand drivers to identify any emerging needs and/or advancement or deferment of recommended investments. The TWG determined that the key electric demand driver in the Greater Ottawa region to be considered in this sensitivity analysis is electric vehicle (EV) penetration and unforeseen electrification which would cause the load to increase at a faster rate than shown in the forecast; or the potential delay in some projects which could result in less demand than anticipated.

The TWG reviewed EV scenarios and any unforeseen electrification needs to develop high demand growth forecasts by applying 5% additional growth to the growth rate on the extreme summer corrected Normal Growth net load forecasts. The low growth scenario was obtained by reducing the growth rate by 2%.

The impact of sensitivity analysis for the high and low growth scenarios identified the following updates or new station capacity needs. Please refer to Table 6 below.

Under the high growth scenario, the capacity need at the station is advanced by about 1-2 years. At Moulton MTS, under the high growth scenario, the station marginally exceeds its capacity for the years 2024-2026. Under the low growth scenario, several stations are near or reaching their capacity, but do not exceed it.

Table 6: Needs Resulting from Sensitivity Analysis

No.	Station Capacity Need	Normal Growth Scenario	High Growth Scenario	Low Growth Scenario
1.	Carling TS	2028	2028	2029
2.	Cyrville MTS	2028	2027	2028
3.	Greely DS	2024	2022	2024
4.	King Edward TS	2024	2023	2025
5.	Lisgar TS	2026	2024	2028
6.	Moulton MTS	N/A	2024-2026	N/A
7.	Nepean Epworth	N/A	2022	N/A
8.	Riverdale TS	2029	2027	N/A
9.	Russell TS*	2028	2026	N/A
10.	South March TS	2026	2024	2027

\* Based on the existing station LTR. As discussed in Section 7, the transformers will be upgraded by 2026.

The high growth sensitivity analysis did not identify additional capacity needs at other stations.

Review of the loading on L2M also shows that under the high growth scenario, the need is advanced from 2031 to 2029.

## 9 CONCLUSION AND RECOMMENDATIONS

The TWG's recommendations are as follows:

- a) Further assessment and regional coordination is required in the next phases of the regional planning cycle to develop a preferred plan for the following needs:
  - Asset renewal needs for South March TS and Lisgar TS to right-size the transformer replacement (discussed in sections 7.1.1 and 7.1.2);
  - Asset renewal needs for section of circuit S7M to determine prefer supply configuration for the area (discussed in section 7.1.4);
  - L2M Supply Capacity (discussed in section 7.2.2); and,
  - Review of station transformation capacity, including the Kanata-Stittville capacity need (discussed in section 7.2.3).

## 10 REFERENCES

1. Hydro One, [RIP Report – Greater Ottawa \(Second cycle\)](#), published on December 18, 2020
2. Independent Electricity System Operator, [IRRP Report – Greater Ottawa \(Second cycle\)](#), published on March 4, 2020
3. Independent Electricity System Operator, [SA Report – Greater Ottawa \(Second cycle\)](#), published on September 12, 2018
4. Hydro One, [NA Report – Greater Ottawa \(Second cycle\)](#), published on June 15, 2018
5. Independent Electricity System Operator, [Ontario Resource and Transmission Assessment Criteria \(ORTAC\) – Issue 5.0 August 07, 2007](#)
6. City of Ottawa, [Community Energy Plan Terms of Reference](#)
7. Independent Electricity System Operator, [Gatineau Corridor End-of-Life Study](#), published on December 2022

## Appendix A: Extreme Summer Weather Net Non-Coincident Load Forecast

*Table A.1: Non-Coincident- Normal Growth Net Load Forecast (all number shown in MW)*

Station	LTR	2022	2023	2024	2025	2026	2027	2028	2029	2030	2031
<b>Center 115kV</b>											
King Edward TS	87	78.2	83.5	87.9	89.8	90.4	90.2	89.6	89.0	88.4	90.1
Lisgar TS	74.7	62.2	69.5	71.5	72.7	75.0	76.2	77.2	79.7	79.5	91.7
Overbrook TS	119.4	68.1	71.4	78.1	84.6	89.0	92.9	93.5	93.8	93.7	93.9
Riverdale TS	105.8	84.9	90.4	93.8	96.4	99.2	101.2	104.6	106.6	107.0	107.6
Russell TS	73.9	58.9	62.5	64.7	67.7	70.6	72.9	74.3	74.7	75.2	74.7
Slater TS	154	104.3	106.1	107.8	109.7	110.9	111.4	110.6	109.8	109.1	109.1
<b>Center 230kV</b>											
Albion TS	94.4	63.0	66.0	66.9	70.0	71.2	72.2	72.0	71.5	71.0	70.5
Ellwood MTS	45	46.5	48.3	50.2	50.5	50.2	49.9	49.5	49.2	48.8	48.5
Hawthorne TS	150.6	121.0	122.9	127.5	129.8	130.5	111.8	113.2	114.3	115.4	116.6
230-44 KV MTS	TBD	0.0	0.9	6.3	8.1	14.4	22.5	28.8	40.5	52.2	63.0
New South-East Station	TBD	0.0	0.0	0.0	0.0	0.0	31.9	34.6	38.2	41.8	44.5
<b>East 115kV</b>											
Bilberry Creek TS	90.2	56.9	57.5	57.8	58.1	58.3	58.1	0.0	0.0	0.0	0.0
Cumberland DS	7	5.8	5.9	6.0	6.0	6.0	6.1	6.2	6.2	6.3	6.3
Cyrville MTS	45	31.2	33.9	35.5	38.5	41.3	44.9	48.3	51.5	52.1	52.7
Moulton MTS	30	28.1	28.1	28.9	28.9	28.8	28.6	28.4	28.1	28.0	27.8
Navan DS	14	4.7	4.7	4.7	4.7	4.7	4.8	4.8	4.8	4.8	4.8
NRC TS	77	22.3	22.3	22.3	22.3	22.3	22.3	36.7	36.7	36.7	36.7
Orleans TS <sup>1</sup>	123.5	53.8	54.7	55.5	56.6	58.2	59.4	0.0	0.0	0.0	0.0
Wilhaven DS	35	9.1	9.2	9.2	9.2	9.2	9.2	9.2	9.2	9.2	9.2
<b>East 230kV</b>											
Brian Coburn MTS	TBD	0.0	0.0	0.0	0.0	0.0	0.0	81.7	82.5	83.4	84.3
Orleans TS <sup>1</sup>	123.5	53.8	54.7	55.5	56.6	58.2	59.4	106.8	106.9	107.1	107.2
<b>Outer East 115kV</b>											
Clarence DS	3	2.7	2.7	2.7	2.7	2.7	2.7	2.7	2.7	2.7	2.8
Hawkesbury MTS	18	13.8	14.2	14.1	14.1	14.2	14.3	14.4	14.4	14.5	14.6
Rockland DS	13	8.2	8.2	8.2	8.2	8.2	8.2	8.2	8.3	8.3	8.3
Rockland East DS	8	13.6	13.6	13.7	13.7	13.7	13.7	13.8	13.8	13.8	13.8
Wendover DS	14	14.1	14.3	14.3	14.4	14.4	14.5	14.6	14.7	14.7	14.8
<b>Outer East 230kV</b>											
Ivaco CTS	100	70.9	70.9	70.9	70.9	70.9	70.9	70.9	70.9	70.9	70.9
Longueuil TS	87.8	43.2	43.4	43.2	43.5	43.7	43.7	44.0	44.3	44.6	44.9
St. Isidore TS	120.5	41.9	42.2	42.3	42.5	42.7	42.9	43.1	43.3	43.6	45.2



<b>Outer West 115kV</b>											
Arnprior TS	46.2	38.3	38.5	38.5	38.5	38.7	38.7	38.9	39.0	40.5	42.2
Stewartville TS	50.4	29.1	29.8	30.2	30.4	30.6	30.8	31.0	31.0	31.2	31.4
<b>Outer West 230kV</b>											
Almonte TS	104	53.4	54.9	55.6	56.6	57.8	58.8	59.9	60.7	65.7	67.5
<b>South 115kV</b>											
Greely DS	21	20.8	21.0	21.8	23.1	24.4	25.6	26.8	28.0	28.0	28.1
Limebank MTS	89	47.8	54.0	62.0	66.1	70.2	61.1	65.2	69.1	73.1	77.0
Marionville DS	14	14.8	15.0	15.6	16.1	16.1	16.1	16.1	16.1	16.1	16.1
NRC Uplands	14	9.7	9.7	9.7	9.7	9.7	9.7	9.7	9.7	9.7	9.7
Russell DS	7	4.4	4.4	4.4	4.4	4.4	4.4	4.4	4.4	4.4	4.5
South Gloucester DS	7	4.7	4.7	4.8	4.8	4.8	4.8	4.8	4.8	4.8	4.8
Uplands MTS	54	36.2	39.8	40.3	41.0	41.2	39.8	40.0	40.1	40.2	40.8
Fallowfield DS	23	26.7	28.9	23.5	24.7	25.6	25.8	31.4	31.2	31.0	30.8
Manotick DS	8	10.0	10.7	11.4	12.1	12.1	12.2	12.2	12.3	12.3	12.4
Richmond MTS	68	20.1	20.9	23.1	27.0	30.4	34.1	39.3	44.6	49.2	52.4
<b>West 115kV</b>											
Bridlewood MTS	23	18.3	19.8	19.7	19.6	20.3	20.2	20.0	20.7	20.6	20.4
Carling TS	100.7	70.5	76.0	87.0	91.9	94.4	95.8	101.0	106.5	106.7	106.7
Centrepont MTS	13	17.8	17.6	17.5	17.4	17.3	17.2	17.0	16.9	16.8	16.7
Hinchey TS	86	29.0	34.2	38.8	46.8	51.2	55.4	58.9	60.7	61.9	63.0
Lincoln Heights TS	71.8	47.4	48.3	48.9	56.8	57.8	59.5	68.0	67.9	67.8	67.7
Manordale MTS	9	8.6	8.6	8.6	8.5	8.5	8.5	8.4	8.4	8.4	8.3
Marchwood MTS	30	49.8	42.0	42.1	45.8	48.6	49.2	49.3	49.0	49.6	49.3
Merivale MTS	23	15.8	18.3	18.2	18.0	17.9	17.8	17.6	17.5	17.4	17.3
Nepean Epworth MTS	13	12.5	12.5	12.4	12.7	12.6	12.6	12.5	12.4	12.6	12.5
Woodroffe TS	96	40.6	41.3	43.4	60.4	61.4	60.6	63.2	63.0	62.8	62.6
<b>West 230kV</b>											
Cambrian MTS	90	20.7	24.7	38.7	40.9	42.9	44.2	62.1	63.4	72.2	84.6
Kanata MTS	49	53.2	55.3	60.4	64.2	64.1	61.0	60.6	60.9	63.4	63.0
Nepean TS	152.6	141.2	144.8	135.9	136.1	137.5	137.5	137.5	136.5	140.1	139.2
South March TS	116.2	98.7	101.9	113.8	116.0	118.1	118.8	119.3	120.2	120.1	128.5
Terry Fox MTS	81	67.8	81.7	85.5	88.4	90.2	91.5	92.2	92.6	93.1	94.5

<sup>1</sup>Current Orleans TS supply configuration is from 230kV circuit D5A and 115kV circuit H9A. Each circuit is assumed to supply half the station load. As discussed in Section 6, once Bilberry Creek TS is retired and Orleans TS converted to dual 230kV supply, the capacity will increase, and the station will only be part of the East 230kV.

**Table A.2: Coincident- Normal Growth Net Load Forecast (all number shown in MW)**

Station	2022	2023	2024	2025	2026	2027	2028	2029	2030	2031
<b>Center 115kV</b>										
King Edward TS	77.2	82.6	86.9	88.9	89.5	89.2	88.7	88.0	87.5	89.2
Lisgar TS	59.1	66.3	68.4	69.6	71.9	73.1	74.1	76.5	76.4	88.6
Overbrook TS	68.1	71.4	78.1	84.6	89.0	92.9	93.5	93.8	93.7	93.9
Riverdale TS	84.9	90.4	93.8	96.4	99.2	101.2	104.6	106.6	107.0	107.6
Russell TS	58.9	61.3	62.3	63.4	64.2	64.6	64.5	64.0	63.6	63.2
Slater TS	104.3	106.1	107.8	109.7	110.9	111.4	110.6	109.8	109.1	109.1
<b>Center 230kV</b>										
Albion TS	60.7	63.6	64.4	67.6	68.8	69.8	69.9	69.4	68.9	68.4
Ellwood MTS	43.3	45.1	47.0	47.3	47.0	46.7	46.3	46.0	45.6	45.3
Hawthorne TS	120.4	122.2	126.9	129.1	129.8	111.2	112.5	113.6	114.7	115.9
230-44 KV MTS	0.0	0.9	6.3	8.1	14.4	22.5	28.8	40.5	52.2	63.0
New South-East Station	0.0	0.0	0.0	0.0	0.0	31.9	34.6	38.2	41.8	44.5
<b>East 115kV</b>										
Bilberry Creek TS	56.9	57.5	57.8	58.1	58.3	58.1	0.0	0.0	0.0	0.0
Cumberland DS	5.8	5.9	5.9	6.0	6.0	6.1	6.1	6.2	6.2	6.3
Cyrville MTS	31.2	33.9	35.5	37.5	38.4	39.2	39.8	40.3	40.9	41.4
Moulton MTS	26.8	26.8	27.6	27.6	27.4	27.2	27.0	26.8	26.6	26.5
Navan DS	4.6	4.7	4.7	4.7	4.7	4.7	4.7	4.8	4.8	4.8
NRC TS	5.2	5.2	5.2	5.2	5.1	5.1	16.9	16.8	16.7	16.7
Orleans TS	47.9	49.1	50.3	51.9	54.1	56.0	0.0	0.0	0.0	0.0
Wilhaven DS	8.9	8.9	8.9	8.9	8.9	8.9	8.9	9.0	9.0	9.0
<b>East 230kV</b>										
Brian Coburn MTS	0.0	0.0	0.0	0.0	0.0	0.0	71.0	71.8	72.7	73.6
Orleans TS	47.9	49.1	50.3	51.9	54.1	56.0	102.1	103.4	103.6	103.6
<b>Outer East 115kV</b>										
Clarence DS	2.5	2.5	2.5	2.5	2.5	2.5	2.5	2.5	2.5	2.5
Hawkesbury MTS	13.6	13.9	13.8	13.8	13.9	14.0	14.0	14.1	14.1	14.2
Rockland DS	8.2	8.2	8.2	8.2	8.2	8.2	8.2	8.3	8.3	8.3
Rockland East DS	13.6	13.6	13.7	13.7	13.7	13.7	13.8	13.8	13.8	13.8
Wendover DS	5.1	5.1	5.1	5.0	5.0	5.0	5.0	5.0	5.0	5.0
<b>Outer East 230kV</b>										
Ivaco CTS	63.8	63.8	63.7	63.5	63.4	63.2	63.2	63.1	62.9	62.8
Longueuil TS	30.4	30.5	30.5	30.5	30.5	30.5	30.6	30.9	31.0	31.3
St. Isidore TS	31.3	31.4	31.4	31.4	31.5	31.5	31.7	31.7	31.8	33.3
<b>Outer West 115kV</b>										
Arnprior TS	33.5	33.5	33.5	33.5	33.6	33.6	33.7	33.7	35.2	36.8
Stewartville TS	26.9	27.0	27.0	27.0	27.1	27.2	27.3	27.3	27.4	27.5

<b>Outer West 230kV</b>										
Almonte TS	46.2	46.8	46.9	47.0	47.0	47.4	47.8	48.0	52.2	53.3
<b>South 115kV</b>										
Greely DS	19.0	20.4	21.8	23.1	24.4	25.6	26.8	28.0	28.0	28.1
Limebank MTS	47.8	54.0	62.0	66.1	70.2	61.1	65.2	69.1	73.1	77.0
Marionville DS	14.4	15.0	15.6	16.1	16.1	16.1	16.1	16.1	16.1	16.1
NRC Uplands CTS	0.5	0.5	0.5	0.5	0.5	0.5	0.5	0.5	0.5	0.5
Russell DS	4.3	4.3	4.3	4.3	4.4	4.4	4.4	4.4	4.4	4.4
South Gloucester DS	4.0	4.0	4.0	4.0	4.0	4.0	4.0	4.0	4.0	4.0
Uplands MTS	35.3	39.0	39.5	40.1	40.3	39.0	39.1	39.2	39.4	39.9
Fallowfield DS	26.7	28.9	23.5	24.7	25.6	25.8	31.4	31.2	31.0	30.8
Manotick DS	10.0	10.7	11.4	12.1	12.1	12.2	12.2	12.3	12.3	12.4
Richmond MTS	11.1	12.0	14.1	18.0	21.5	25.1	30.3	35.6	40.2	43.4
<b>West 115kV</b>										
Bridlewood MTS	18.3	19.8	19.7	19.6	20.3	20.2	20.0	20.7	20.6	20.4
Carling TS	65.4	70.9	82.0	86.8	89.4	90.7	95.9	101.5	101.7	101.6
Centrepont MTS	17.8	17.6	17.5	17.4	17.3	17.2	17.0	16.9	16.8	16.7
Hinchey TS	29.0	34.2	38.8	46.8	51.2	55.4	58.9	60.7	61.9	63.0
Lincoln Heights TS	47.4	48.3	48.9	56.8	57.8	59.5	68.0	67.9	67.8	67.7
Manordale MTS	8.6	8.6	8.6	8.5	8.5	8.5	8.4	8.4	8.4	8.3
Marchwood MTS	37.6	42.0	41.2	42.2	42.8	43.4	43.5	43.2	43.8	43.5
Merivale MTS	14.9	17.3	17.2	17.1	17.0	16.8	16.7	16.6	16.5	16.3
Nepean Epworth MTS	11.2	11.2	11.1	11.4	11.3	11.3	11.2	11.1	11.3	11.2
Woodroffe TS	37.2	37.9	40.0	57.0	58.1	57.2	59.8	59.6	59.4	59.3
<b>West 230kV</b>										
Cambrian MTS	20.7	24.7	38.7	40.9	42.9	44.2	45.9	47.2	53.7	55.4
Kanata MTS	53.2	55.3	60.4	64.2	64.1	61.0	60.6	60.9	63.4	63.0
Nepean TS	131.0	134.6	125.7	125.9	127.3	127.3	127.3	126.3	129.9	129.1
South March TS	54.3	56.8	68.2	69.9	71.5	71.6	71.6	72.0	71.4	77.2
Terry Fox MTS	67.8	81.7	85.5	88.4	90.2	91.5	92.2	92.6	93.1	94.5

## Appendix B: Distributors in the Greater Ottawa Region

Distributor Name	Station Name	Connection Type
Hydro 2000	Longueuil TS	Dx
Hydro Hawkesbury	Hawkesbury MTS	Tx
	Longueuil TS	Dx
Hydro One	Almonte TS	Tx
	Arnprior TS	Tx
	Bilberry Creek TS	Tx
	Clarence DS	Tx
	Cumberland DS	Tx
	Greely DS	Tx
	Hawthorne TS	Tx
	Longueuil TS	Tx
	Manotick DS	Tx
	Marionville DS	Tx
	Navan DS	Tx
	Orleans TS	Tx
	Rockland DS	Tx
	Rockland East DS	Tx
	Russell DS	Tx
	South Gloucester DS	Tx
	St Isidore TS	Tx
	Stewartville TS	Tx
Wilhaven DS	Tx	
Hydro Ottawa	Albion TS	Tx
	Almonte TS	Dx
	Bilberry Creek TS	Tx
	Bridlewood MTS	Tx
	Cambrian MTS	Tx
	Carling TS	Tx
	Centrepont MTS	Tx
	Cyrville MTS	Tx
	Ellwood MTS	Tx
	Nepean Epworth MTS	Tx
	Fallowfield DS	Tx
	Hawthorne TS	Tx
	Hinchey TS	Tx
	Kanata MTS	Tx
King Edward TS	Tx	
Hydro Ottawa	Limebank MTS	Tx

	Lincoln Heights TS	Tx
	Lisgar TS	Tx
	Manordale MTS	Tx
	Marchwood MTS	Tx
	Moulton MTS	Tx
	Merivale MTS	Tx
	Nepean TS	Tx
	Orleans TS	Tx
	Overbrook TS	Tx
	Richmond MTS	Tx
	Riverdale TS	Tx
	Russell TS	Tx
	Slater TS	Tx
	South Gloucester DS	Dx
	South March TS	Dx, Tx
	St Isidore TS	Dx
	Terry Fox MTS	Tx
	Upland MTS	Tx
	Woodroffe TS	Tx
Ottawa River Power Corporation	Almonte TS	Dx
Renfrew Hydro	Stewartville TS	Dx

## Appendix C: Lists of Transmission Circuits

Location	Circuit Designations	Voltage (kV)
Hawthorne TS – Merivale TS	M30A, M31A	230
Hawthorne TS – St Isidore TS	D5A	230
Merivale TS – Almonte TS	E34M (formerly M29C)	230
Merivale TS – South March TS	M32S	230
South March SS – Chats Falls SS	C3S	230
Hawthorne TS – Bilberry Creek TS	A2	115
Hawthorne TS - Merivale TS	A3RM, A8M	115
Hawthorne TS – Overbrook TS	A4K, A5RK	115
Hawthorne TS – Riverdale TS	A6R	115
Hawthorne TS – Hawkesbury MTS	H9A/79M1	115
Merivale TS – Chats Falls TS	C7BM	115
Merivale TS – Hinchey TS	F10MV, V12M	115
Merivale TS – Lisgar TS	M4G, M5G	115
Merivale TS – South March SS	S7M	115
Stewartville TS – South March SS	W6CS	115
Stewartville TS – Barrett Chute TS	W3B	115

## Appendix D: Acronyms

Acronym	Description
A	Ampere
BES	Bulk Electric System
BPS	Bulk Power System
CDM	Conservation and Demand Management
CEP	Community Energy Plan
CIA	Customer Impact Assessment
CGS	Customer Generating Station
CSS	Customer Switching Station
CTS	Customer Transformer Station
DESN	Dual Element Spot Network
DG	Distributed Generation
DS	Distribution Station
GS	Generating Station
HV	High Voltage
IESO	Independent Electricity System Operator
IRRP	Integrated Regional Resource Plan
kV	Kilovolt
LDC	Local Distribution Company
LP	Local Plan
LTE	Long Term Emergency
LTR	Limited Time Rating
LV	Low Voltage
MEP	Municipal Energy Plan
MTS	Municipal Transformer Station
MW	Megawatt
MVA	Mega Volt-Ampere
MVAR	Mega Volt-Ampere Reactive
NA	Needs Assessment
NERC	North American Electric Reliability Corporation
NGS	Nuclear Generating Station
NPCC	Northeast Power Coordinating Council Inc.
NUG	Non-Utility Generator
OEB	Ontario Energy Board
ORTAC	Ontario Resource and Transmission Assessment Criteria
PF	Power Factor
PPWG	Planning Process Working Group
RIP	Regional Infrastructure Plan
SA	Scoping Assessment
SIA	System Impact Assessment
SPS	Special Protection Scheme
SS	Switching Station
STG	Steam Turbine Generator
TS	Transformer Station